

2.00mm(.079") HOUSING

MATERIAL

Insulator: Nylon 66 UL 94V-0
Color: Black or White

SPECIFICATIONS

Temperature range: -25°C ~ +85°C
Current rating: 3A AC/DC
Voltage rating: 250V AC/DC
Dielectric withstand voltage: 650V AC
Insulation resistance: 1000 MΩ Min.
Contact resistance: 0.03Ω Max.

Order Information

R 5530-xxP
1 2 3

1. RoHS
2. Series No.
3. Pin No.

Dimensional Information

Circuits	Dim. A	Dim. B	Dim. C
2	2.00(0.079)	6.00(0.236)	4.45(0.175)
3	4.00(0.157)	8.00(0.315)	6.45(0.254)
4	6.00(0.236)	10.00(0.394)	8.45(0.333)
5	8.00(0.315)	12.00(0.472)	10.45(0.411)
6	10.00(0.394)	14.00(0.551)	12.45(0.490)
7	12.00(0.472)	16.00(0.630)	14.45(0.569)
8	14.00(0.551)	18.00(0.709)	16.45(0.648)
9	16.00(0.630)	20.00(0.787)	18.45(0.726)
10	18.00(0.709)	22.00(0.866)	20.45(0.805)
11	20.00(0.787)	24.00(0.945)	22.45(0.884)
12	22.00(0.866)	26.00(1.024)	24.45(0.963)
13	24.00(0.945)	28.00(1.102)	26.45(1.041)
14	26.00(1.024)	30.00(1.181)	28.45(1.120)
15	28.00(1.102)	32.00(1.260)	30.45(1.199)

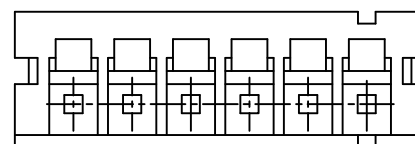
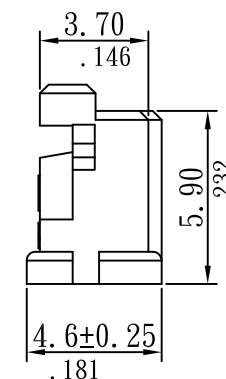
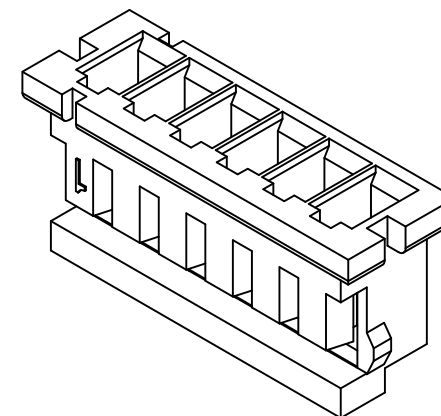
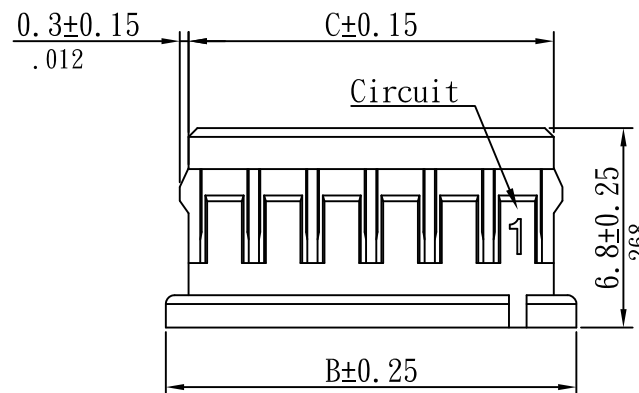
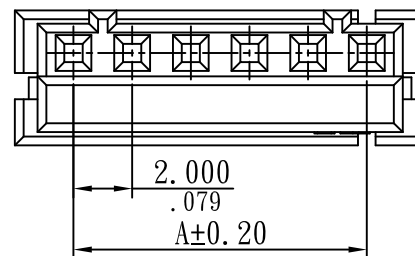

Sunny Young Enterprise Co., Ltd.

S. Y. E. <http://www.sunnyyoung.com.tw>

13F., No. 116, Sec. 1, Xintai 5th Rd., Xizhi Dist., New Taipei City 221, Taiwan

Tel: +886 2 2696 1668(REP) Fax: +886 2 2696 2668

S008	NAME	DATE	SCALE: 1:4	REV NO	DATE	DESCRIPTION	BY	CHECKED	TOLERANCE UNLESS NOTED	
DRAWN	ELLA	2016.05.25	UNIT: mm(in.)	A					LINEAR±	.0 ±0.30(.012)
CHECKED	SEAN	2016.06.03	CAD NO	B						.00 ±0.20(.008)
APPROVED	ANDY	2016.06.03	R5530-xxP	C						.000±0.10(.004)
PART NO R5530-xxP									PROJECTION:	

2.00mm(.079") TERMINAL

SPECIFICATIONS

Material : Phosphor bronze
 Thickness : 0.20mm
 Plating : Tin plated
 Applicable wire : AWG 28 ~ AWG 22
 Insulation O.D. : 1.45mm Max
 Used in S.Y.E. R5530-xxP Housing

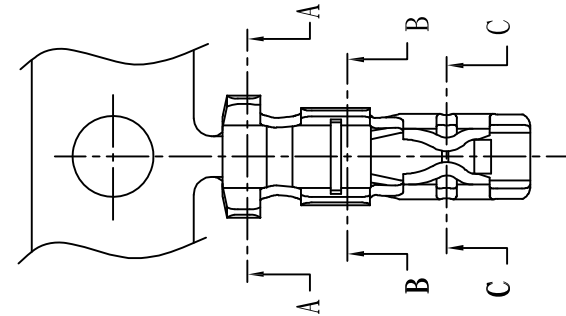

Order Information

R 5533-P T
 1 2 3 4

1. RoHS
2. Series No.
3. Phosphor Bronze
4. Tin Plated

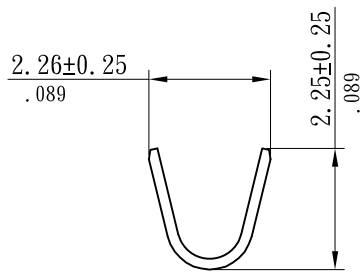

A-A SECTION

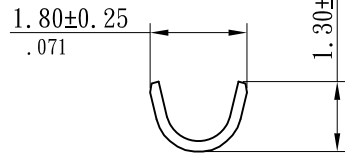

B-B SECTION

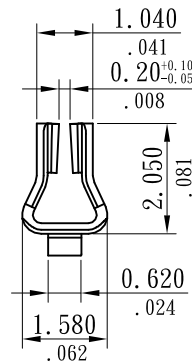

C-C SECTION

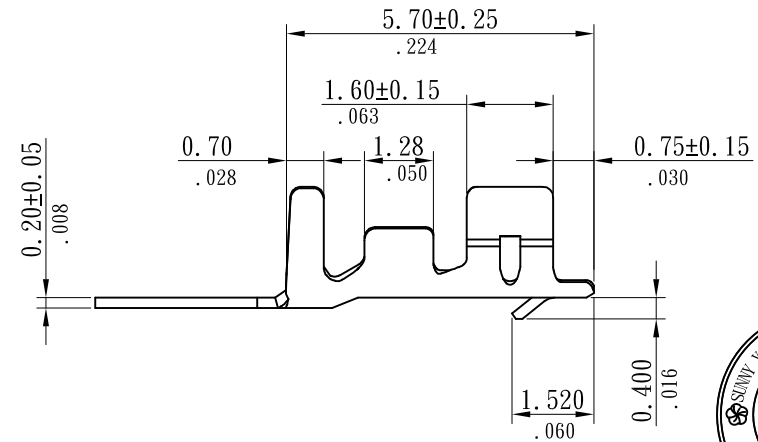

S.Y.E. Sunny Young Enterprise Co., Ltd.
 S. Y. E. <http://www.sunnyyoung.com.tw>
 13F., No. 116, Sec. 1, Xintai 5th Rd., Xizhi Dist., New Taipei City 221, Taiwan
 Tel: +886 2 2696 1668(REP) Fax: +886 2 2696 2668

S008	NAME	DATE	SCALE: NST	REV NO	DATE	DESCRIPTION	BY	CHECKED	TOLERANCE UNLESS NOTED	
DRAWN	ELLA	2016.05.25	UNIT: mm(in.)	A					LINEAR±	.0 ±0.30(.012)
CHECKED	SEAN	2016.06.03	CAD NO	B						.00 ±0.20(.008)
APPROVED	ANDY	2016.06.03	R5533-PT	C						.000±0.10(.004)
									PROJECTION:	

PART NO R5533-PT